



Coaxial Attenuator

Features and Electrical specifications:

Model	ATXXRA20A-SMA-6			
Frequency Range	DC~6.0GHz			
VSWR	1.20Max			
Power	20 W			
Impedance	50 Ω			
Attenuation	01-10dB	11-20dB	25、30dB	40、50、60dB
Attenuation Tolerance	± 0.6 dB	± 0.8 dB	± 1.0 dB	± 1.1 dB
Connector	SMA-J(M)/ SMA-K(F)			
Dimension	$\Phi 36 \times 88.2$ mm			
Operating Temperature	-55 ~ +125°C (See de Power De-rating)			
Weight	About 120 g			
ROHS Compliant	Yes			

Outline Drawing (Unit: mm/inch):

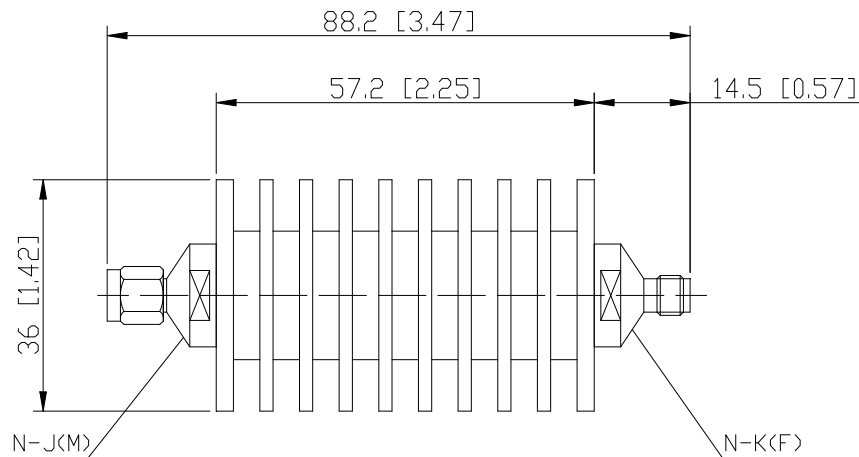
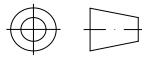



Naming rules:

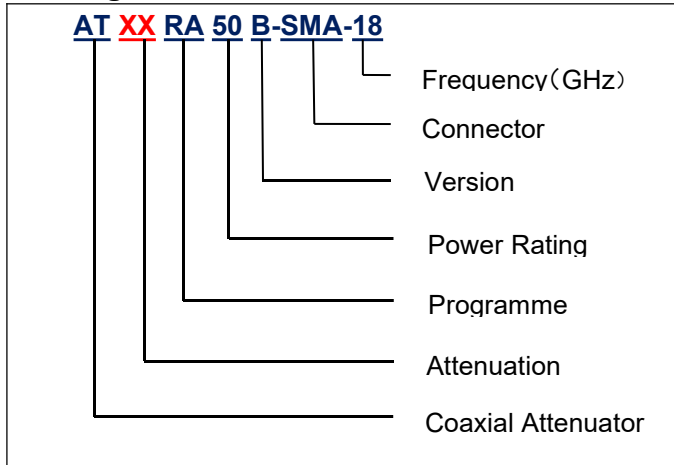

Power De-rating:

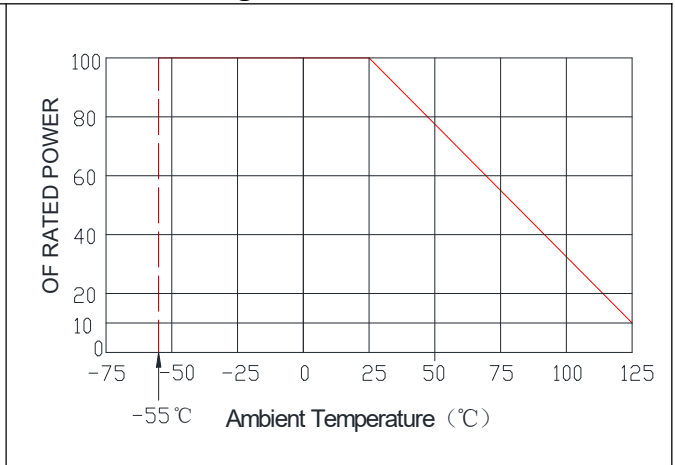

**Graph:
3dB**

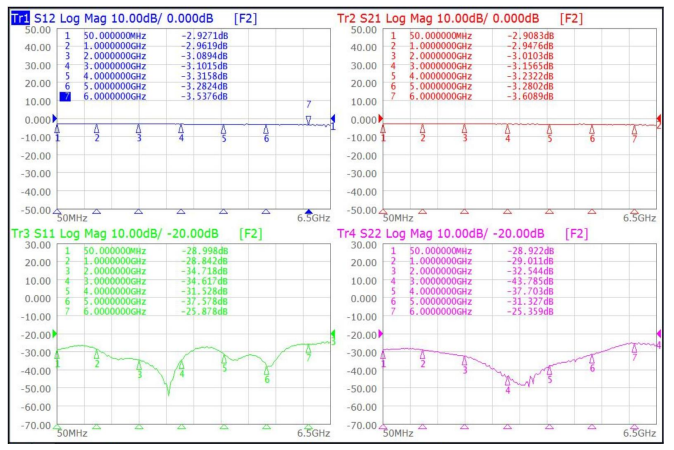

10dB

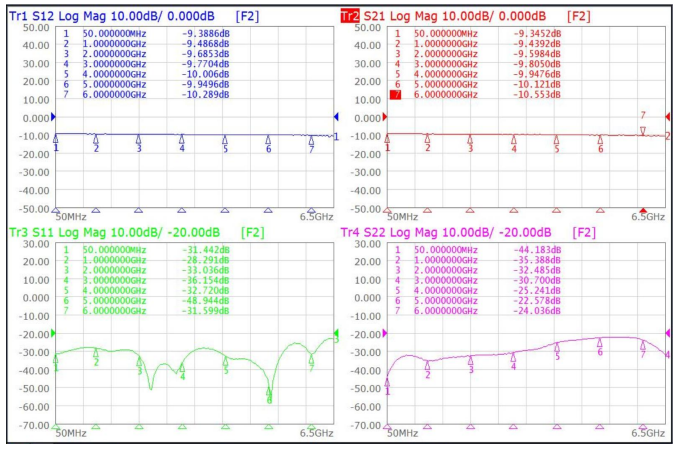

20dB

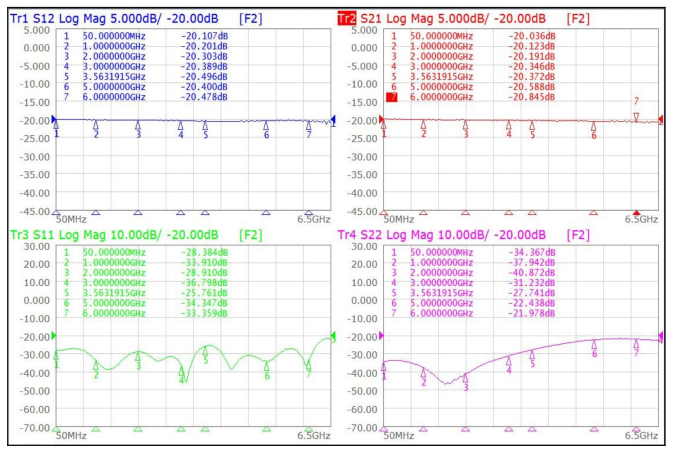

30dB

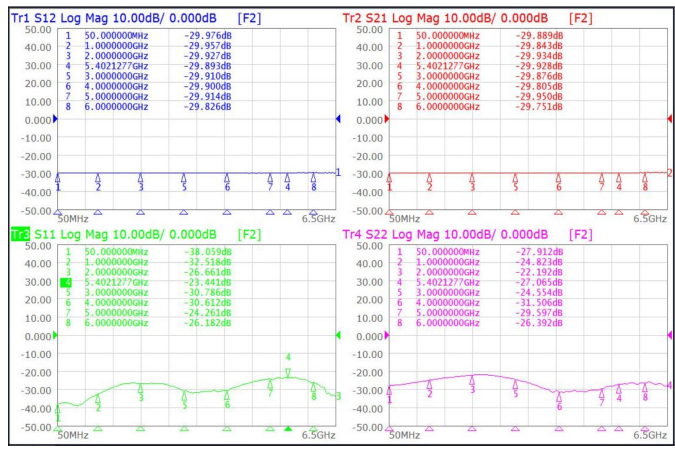



40dB

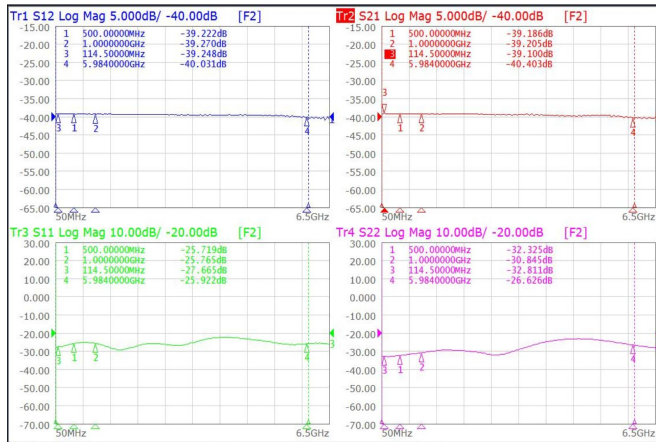

60dB

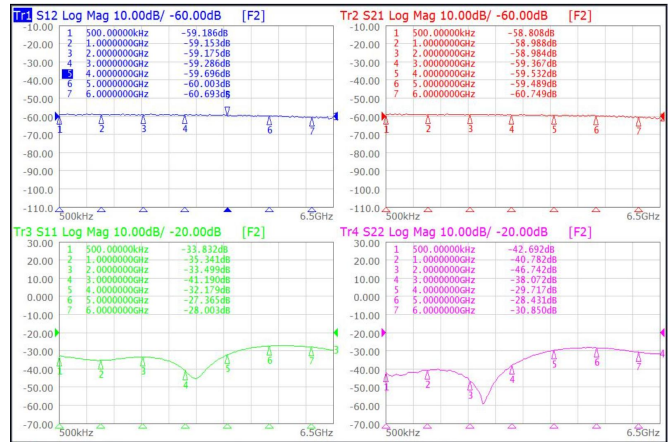

Use attention:

- 1、Dimensions Tolerance $\pm 3\%$;
- 2、If necessary, the product shall be air-cooled for auxiliary heat dissipation ;
- 3、Custom designs available of other special attenuators ;
- 4、Pay attention to the direction of the product during use and strictly prohibit reverse connection.