



Coaxial Attenuator

Features and Electrical specifications:

Model	ATXXRA05A-N-6		
Frequency Range	DC~6.0GHz		
VSWR	1.25Max		
Power	5 W		
Impedance	50 Ω		
Attenuation	1-10dB	12、13、15、20dB	25、30、40dB
Attenuation Tolerance	±0.6dB	±0.8dB	±1.0dB
Connector	N-J(M)/N-K(F)		
Dimension	Φ20×66mm		
Operating Temperature	-55 ~ +125°C (See de Power De-rating)		
Weight	About 80 g		
ROHS Compliant	Yes		

Outline Drawing (Unit: mm/inch):

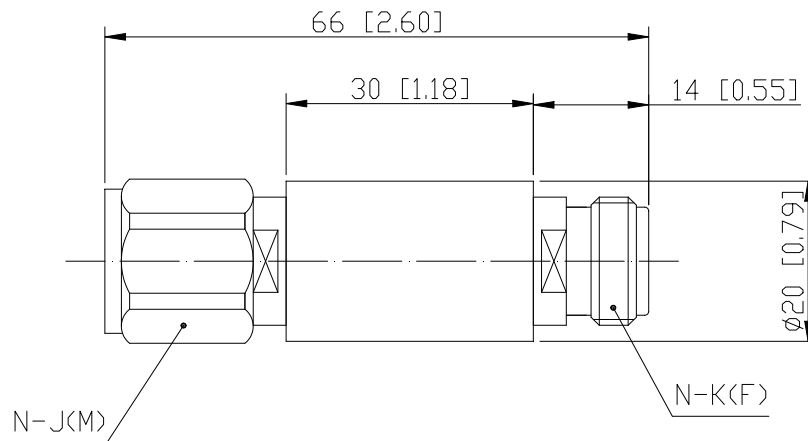
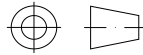

RFTYT Technology Co., LTD.

<http://www.rfyt.com>

E-mail: Jackson@rfyt.com zqc7708@rfyt.com

TEL: +86-13088268828 FAX: +86-816-2846565

218# Wenwu Middle Road, Jinkai District, Mianyang, Sichuan Province China

Ready For Tackling Your Trouble



Naming rules:

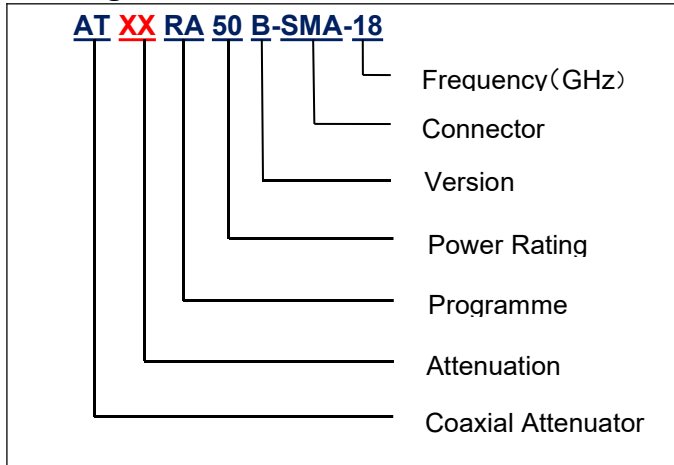

Power De-rating:

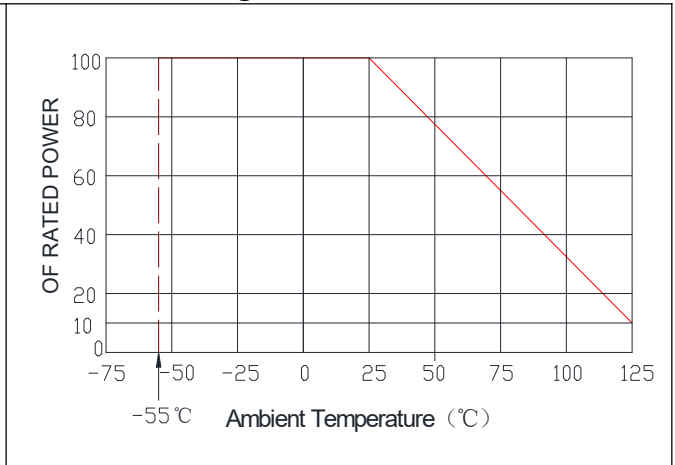

Graph:

2dB

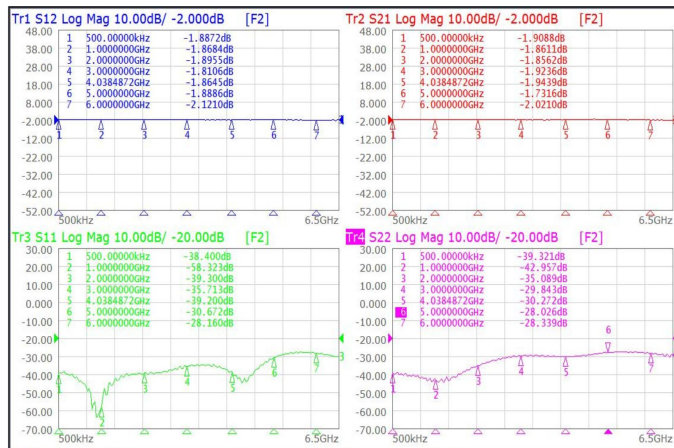

4dB

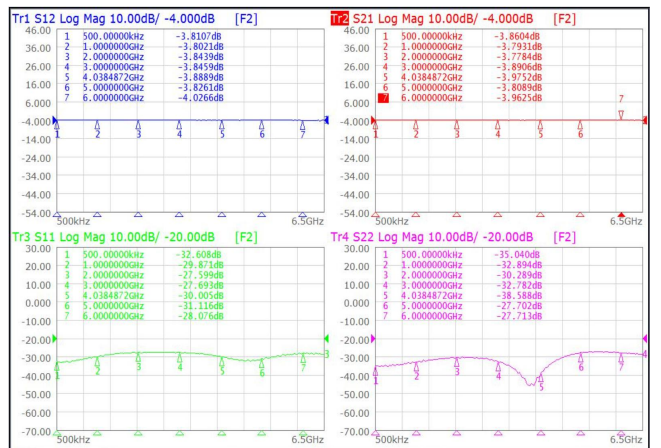

6dB

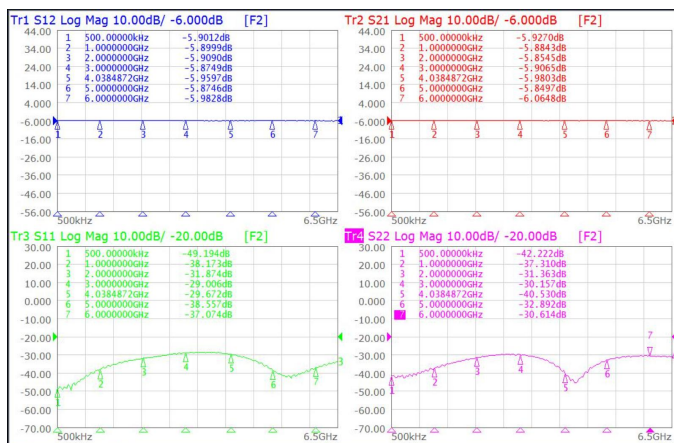

8dB

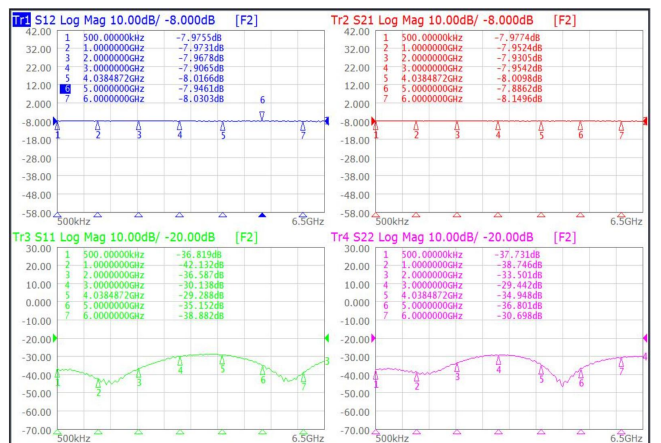



10dB

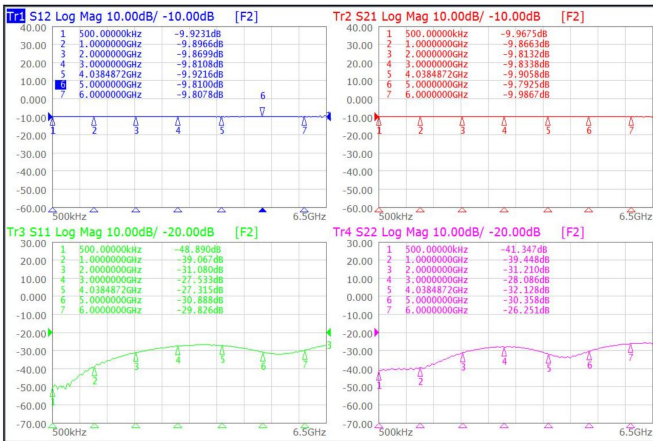

20dB

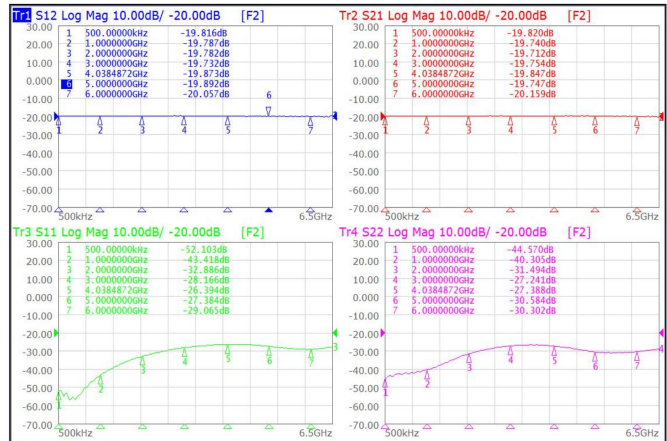

30dB

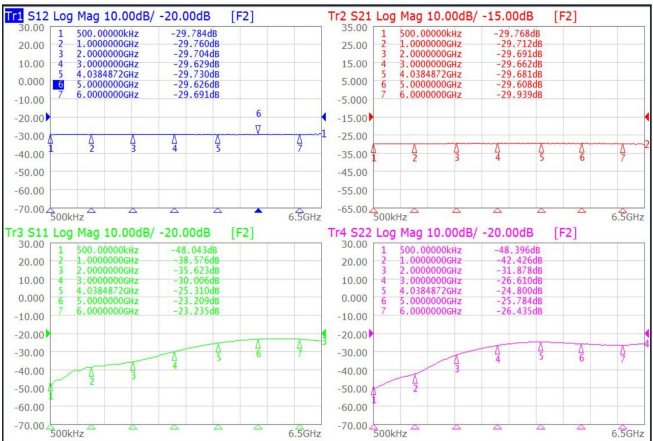

40dB

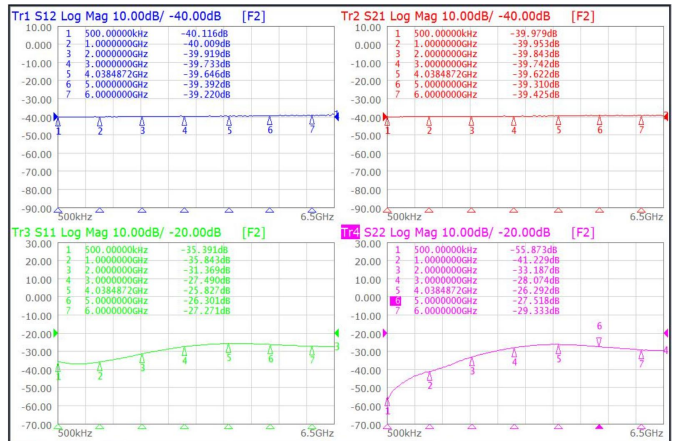

Use attention:

- 1、Dimensions Tolerance $\pm 3\%$;
- 2、If necessary, the product shall be air-cooled for auxiliary heat dissipation ;
- 3、Custom designs available of other special attenuators ;
- 4、Pay attention to the direction of the product during use and strictly prohibit reverse connection.