



Flanged Attenuator

◆Features and Electrical specifications:

Model	RFTXX-30AM1606-6 (XX=Attenuation value)		
Impedance	50 Ω		
Frequency Range	DC~6.0GHz		
VSWR	1.25 max		
Rated Power	30 W		
Attenuation Value(dB)	1-10	15, 20	25, 30
Attenuation Tolerance(dB)	±0.6	±0.8	±1.0
Temperature coefficient	<150ppm/°C		
Substrate Material	BeO		
Porcelain Hat Material	Al ₂ O ₃		
Flange	Nickel-plated copper		
Lead	99.99% Sterling Silver		
Resistance Technology	Thick Film		
Operating Temperature	-55 to +150°C (See de Power De-rating)		

◆Outline Drawing (Unit: mm/inch):

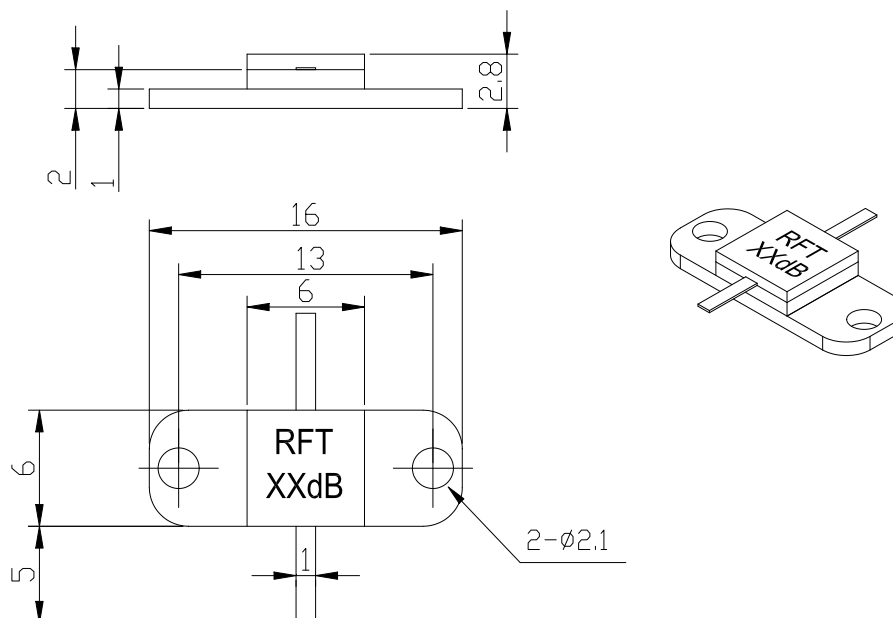

Lead length can be customized according to customer requirements

Dimensional tolerance: 5% unless otherwise stated

RFTYT Technology Co., LTD.

<http://www.rftyt.com>

E-mail: Jackson@rftyt.com

Cerman.wu@rftyt.com

TEL: +86-13088268828

FAX: +86-816-2846565

218# Wenwu Middle Road, Jinkai District, Mianyang, Sichuan Province China

Ready For Tackling Your Trouble



Typical Performance:

3dB Graph

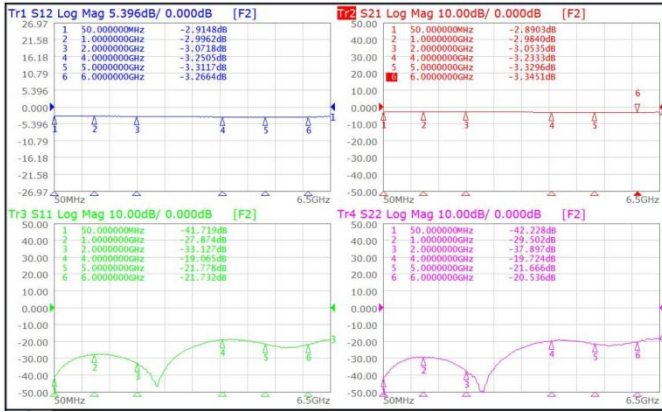

6dB Graph

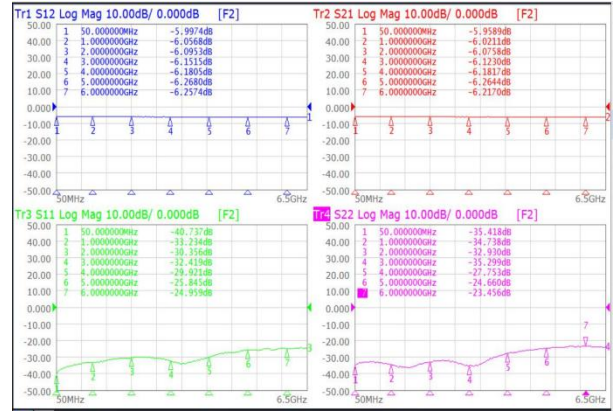

20dB Graph

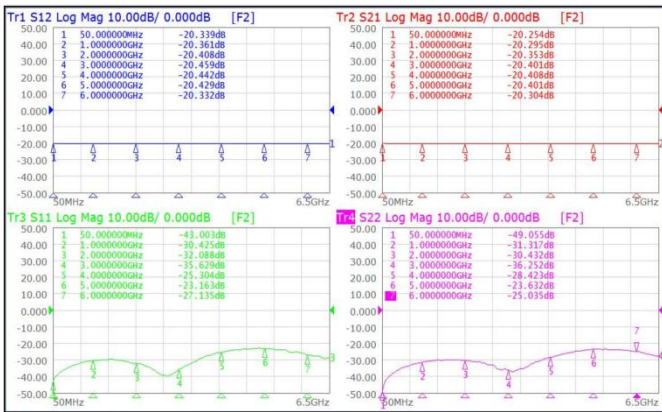

30dB Graph

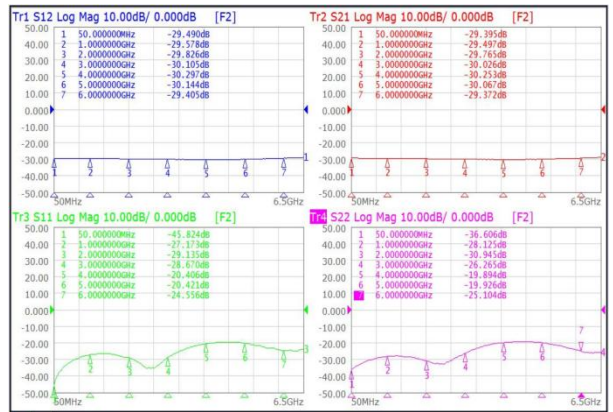

◆Installation Method:

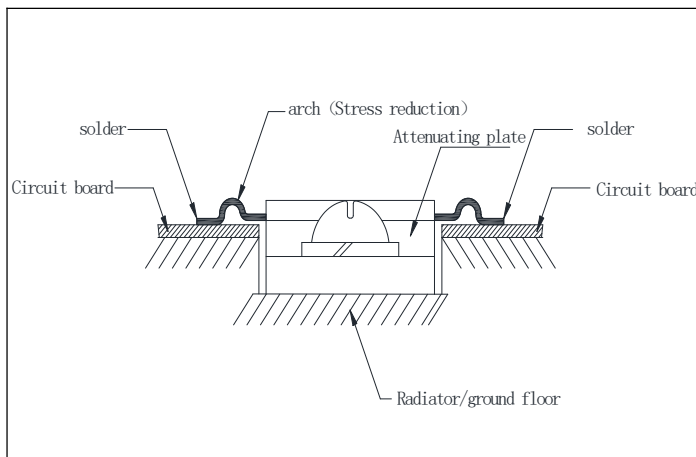

◆Power De-rating:

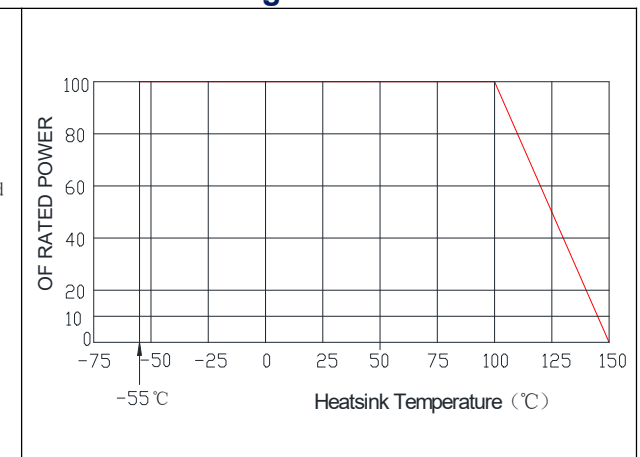



◆ P/N Designation:

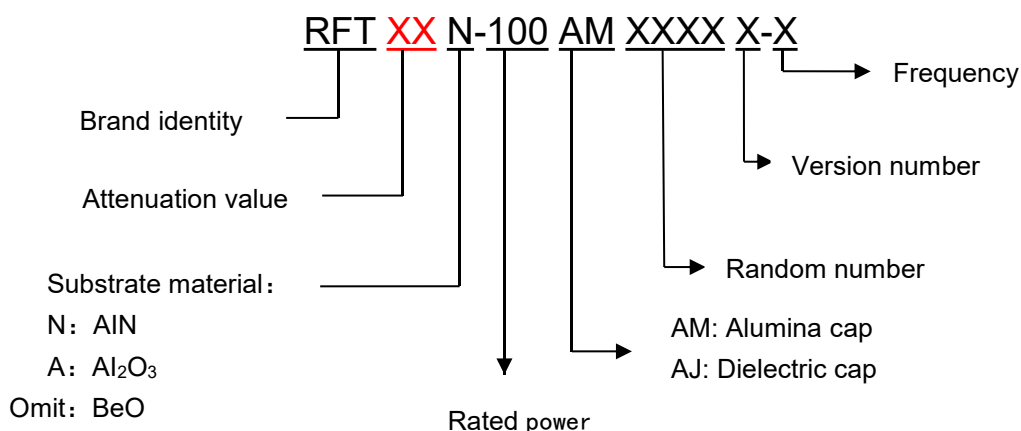

◆ Use attention:

- After the storage period of newly purchased parts exceeds 6 months, attention should be paid to weldability before use. It is recommended to store in vacuum packaging.
- The ground needs optimal heat transfer.
- The manual welding lead should be used under a constant temperature soldering iron of no more than 350 degrees, and the welding time should be controlled within 5 seconds.
- In order to meet the drawing requirements, it is necessary to install a sufficiently large radiator. Metal surfaces and radiators need to be coated with a very thin layer of thermal grease.
- If necessary, add air or water cooling.

◆ Instructions:

- Custom designed RF attenuators, RF resistors and RF terminals are available.