



## Coaxial Fixed Attenuator

### Features and Electrical specifications:

Model	RFTXX-30RA3857-N-4 (XX=Attenuator Value)				
Frequency Range	DC~4.0GHz				
VSWR	1.20Max				
Power	30 W				
Impedance	50 Ω				
Attenuation	01-10dB	11-20dB	21-30dB	40dB	50、60dB
Attenuation Tolerance	±0.8dB	±1.0dB	±1.2dB	±1.2dB	±1.2dB
Connector	N-J(M)/N-K(F)				
Dimension	Φ38×94.2mm				
Operating Temperature	-55 ~ +125°C (See de Power De-rating)				
Weight	About 160 g				
ROHS Compliant	Yes				

### Outline Drawing (Unit: mm/inch):

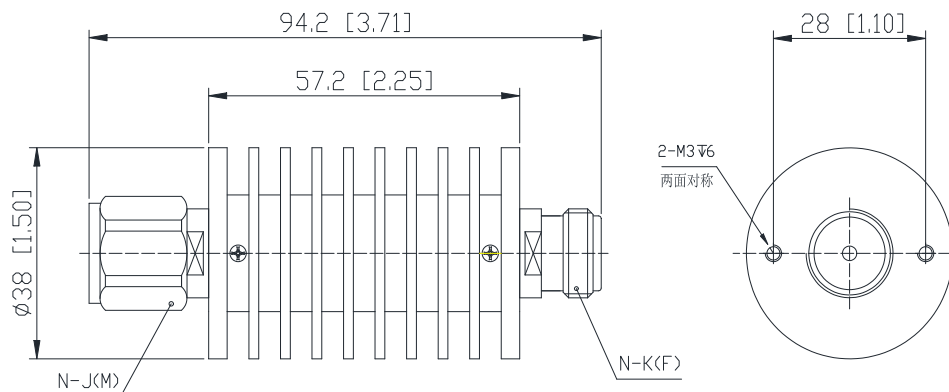

The connector could be 4.3-10, DIN, SMA MM or FF ,  
or any two can be freely mixed and matched



**Naming rules:**

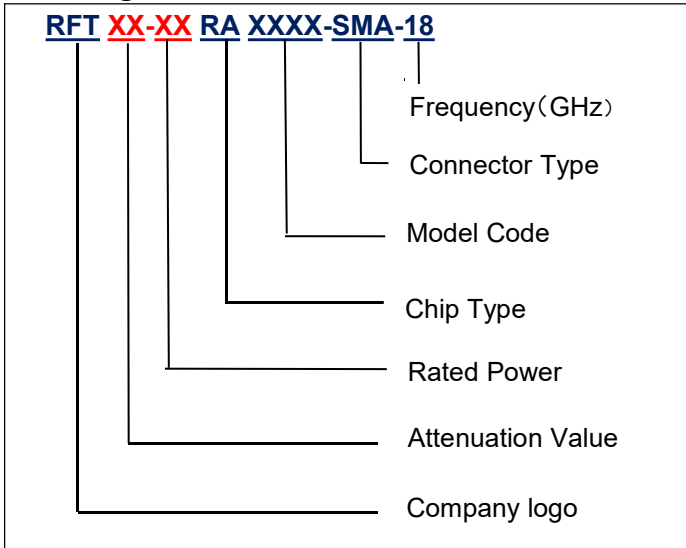

**Power De-rating:**

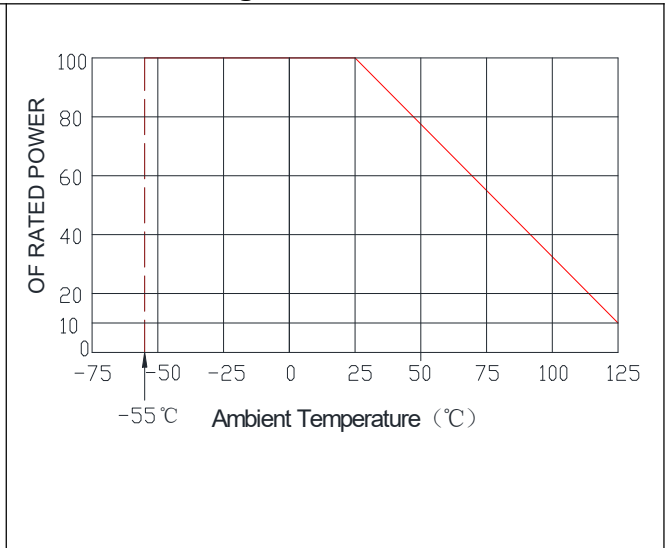

**Graph:**

**3dB**

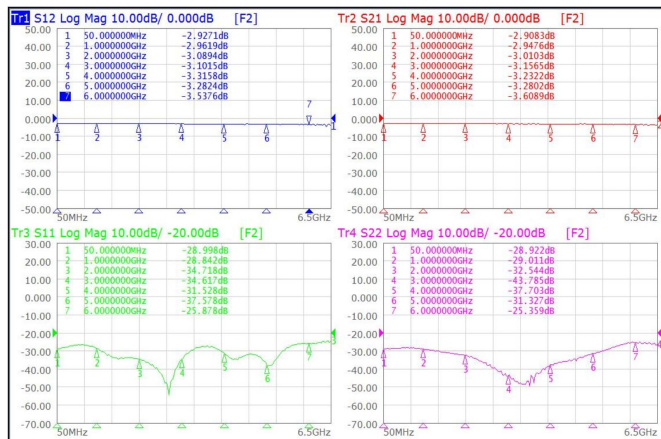

**10dB**

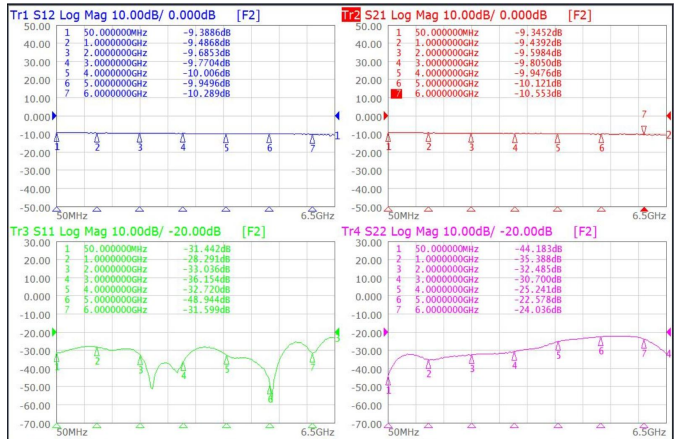

**20dB**

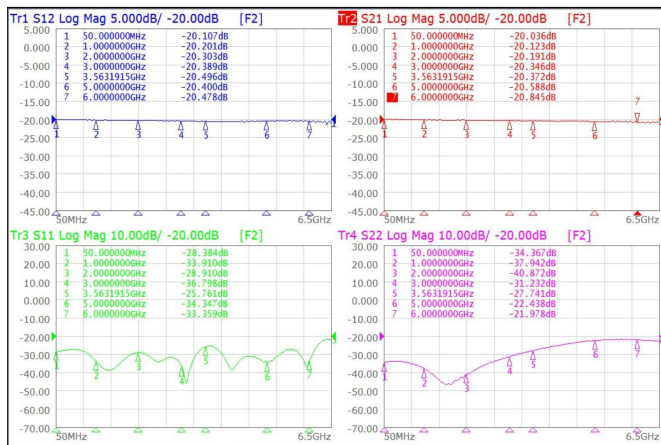

**30dB**

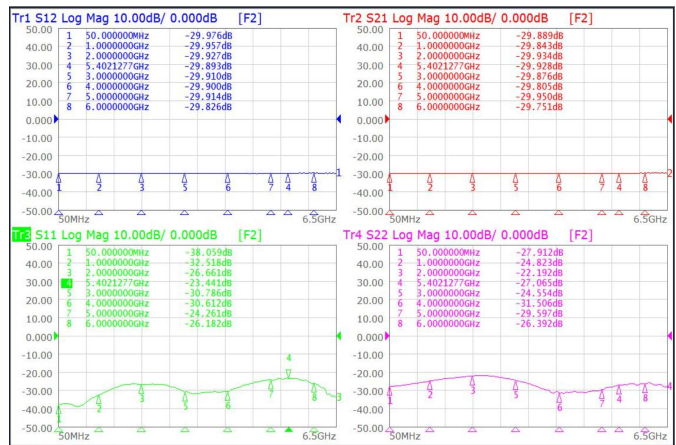



### 40dB

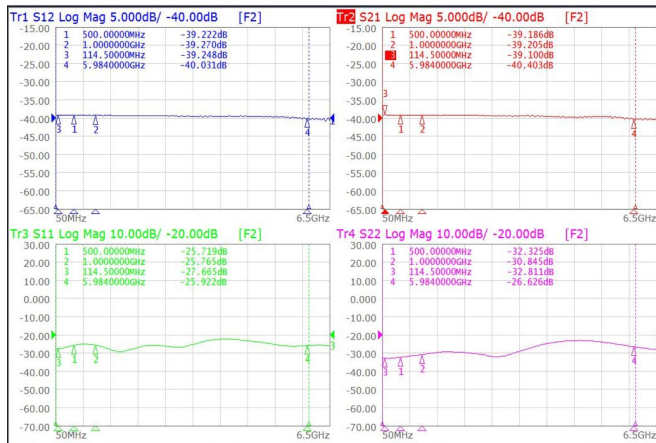

### 60dB

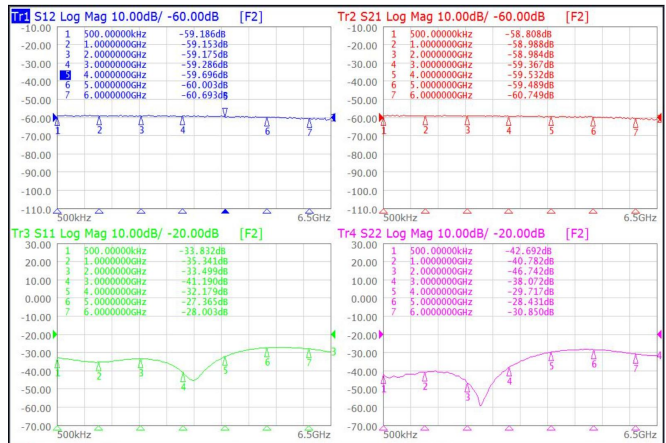

### Use attention:

- 1、Dimensions Tolerance  $\pm 3\%$ ;
- 2、If necessary, the product shall be air-cooled for auxiliary heat dissipation ;
- 3、Custom designs available of other special coaxial fixed attenuator ;
- 4、Pay attention to the direction of the product during use and strictly prohibit reverse connection.