



## Coaxial Fixed Attenuator

### Features and Electrical specifications:

Model	RFTXX-05RA2030-N-4 (XX=Attenuator Value)		
Frequency Range	DC~4.0GHz		
VSWR	1.20 Max		
Power	5 W		
Impedance	50 Ω		
Attenuation	1-10dB	12、13、15、20dB	25、30、40dB
Attenuation Tolerance	±0.6dB	±0.8dB	±1.0dB
Connector	N-J(M)/N-K(F)		
Dimension	Φ20×66mm		
Operating Temperature	-55 ~ +125°C (See de Power De-rating)		
Weight	About 80 g		
ROHS Compliant	Yes		

### Outline Drawing (Unit: mm/inch):

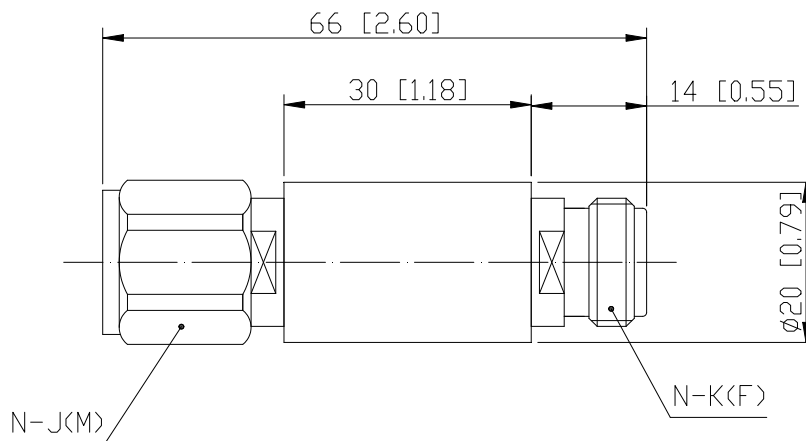

The connector can be SMA, DIN, 4.3-10 MM or FF ,  
or any two can be freely mixed and matched



**Naming rules:**

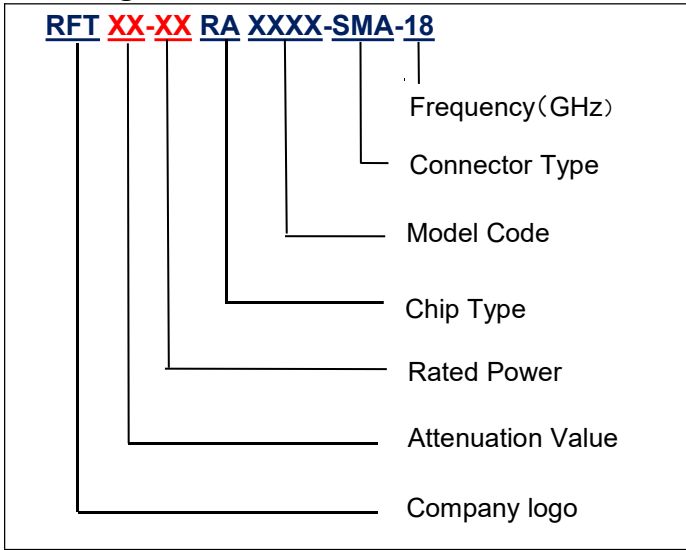

**Power De-rating:**

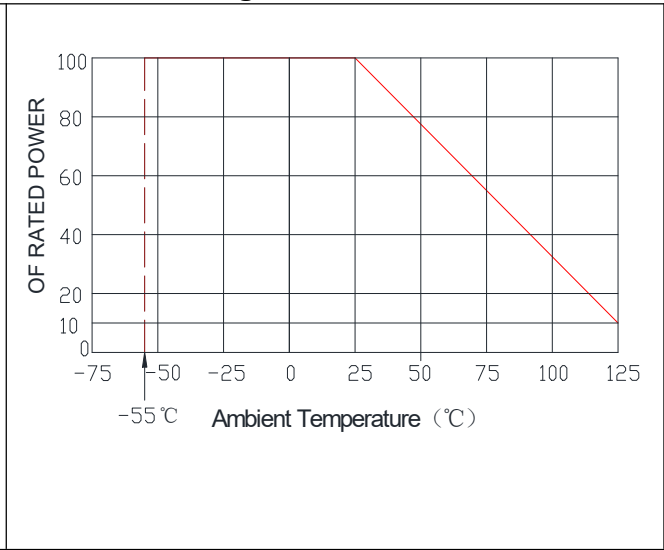

**Graph 2dB**

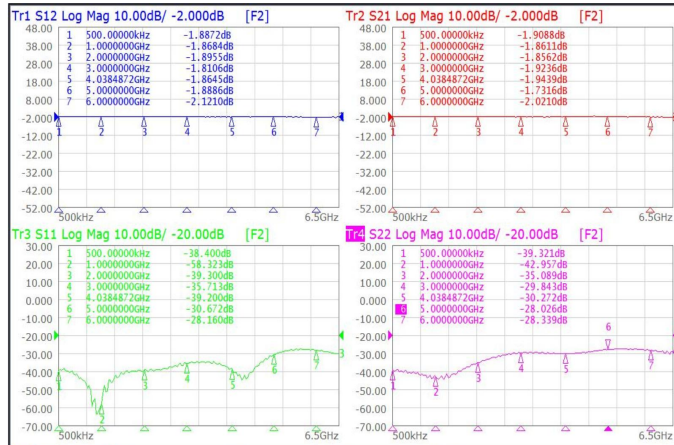

**4dB**

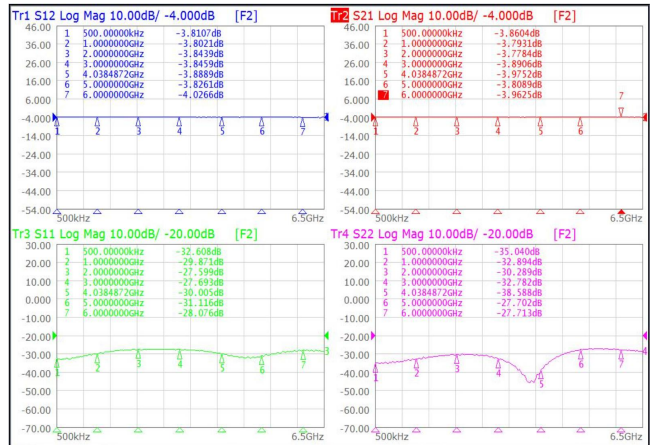

**6dB**

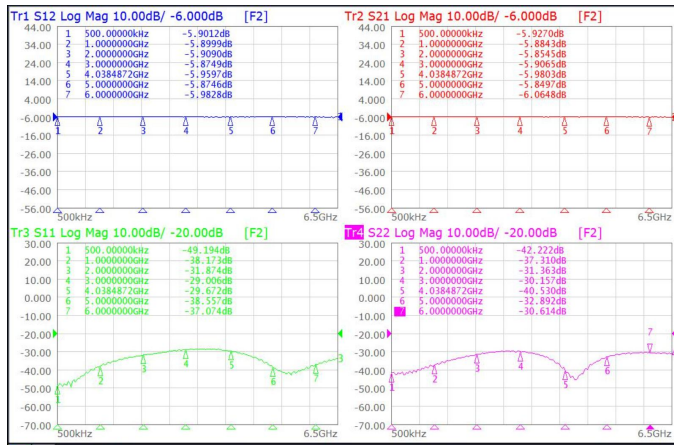

**8dB**

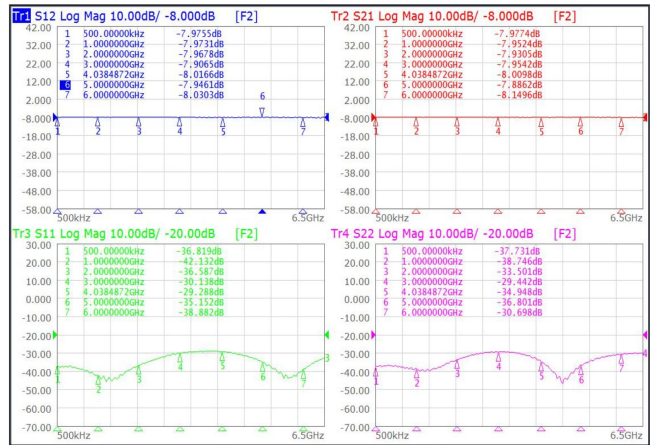



### 10dB

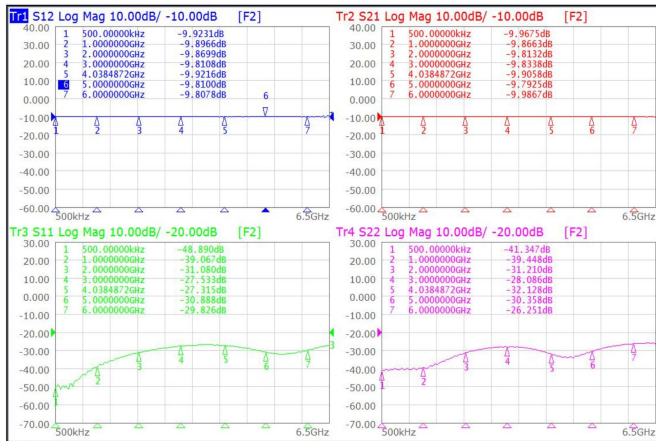

### 20dB

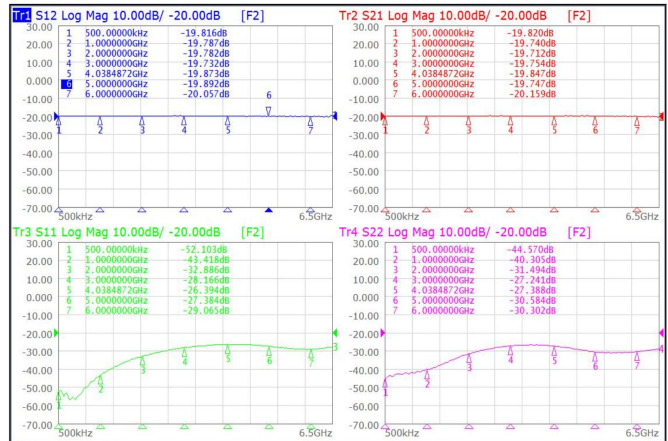

### 30dB

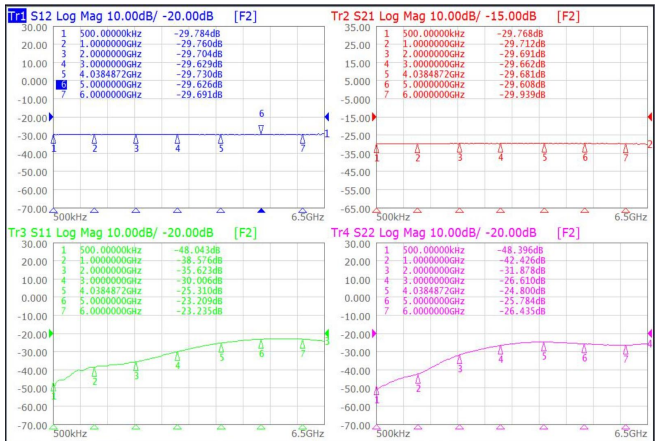

### 40dB

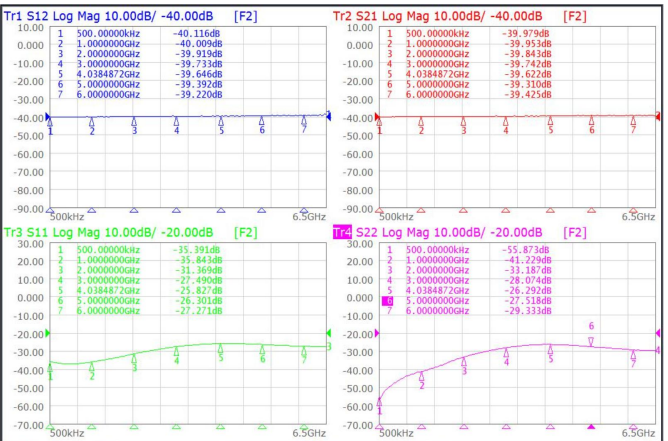

### Use attention:

- 1、Dimensions Tolerance  $\pm 3\%$ ;
- 2、If necessary, the product shall be air-cooled for auxiliary heat dissipation ;
- 3、Custom designs available of other special coaxial fixed attenuator ;
- 4、Pay attention to the direction of the product during use and strictly prohibit reverse connection.