



## Chip Attenuator

### ◆Features and Electrical specifications:

Model	RFTXXN-10CA6363C-3 (XX= Attenuation value)		
Resistance Range	50 Ω		
Frequency Range	DC~3.0GHz		
VSWR	1.25 max		
Power	10 W		
Attenuation Value(dB)	01-10dB	11-20dB	21-30dB
Attenuation Tolerance(dB)	±0.6dB	±0.8dB	±1.0dB
Temperature Coefficient	<150ppm/°C		
Substrate Material	AlN		
Ceramic cap material	Medium		
Resistance Technology	Thick Film		
Operating Temperature	-55 to +150°C (See de Power De-rating)		

### ◆Outline Drawing (Unit: mm/inch):

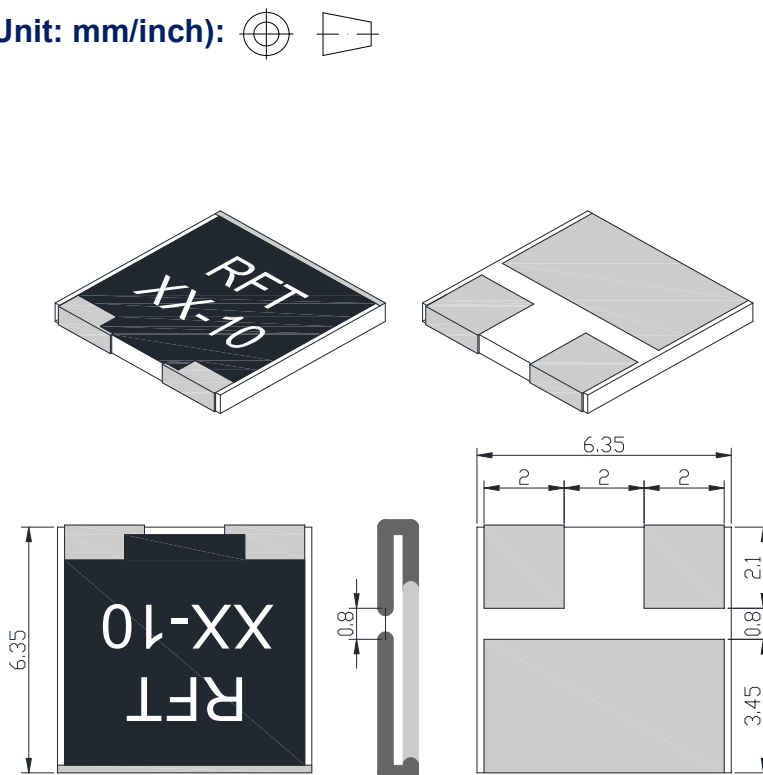

RFTYT Technology Co., LTD.

<http://www.rfyt.com>

E-mail: [jackson@rfyt.com](mailto:jackson@rfyt.com)      [cermen@rfyt.com](mailto:cermen@rfyt.com)

TEL: +86-13088268828      FAX: +86-816-2846565

218# Wenwu Middle Road, Jinkai District, Mianyang, Sichuan Province China

Ready For Tackling Your Trouble



◆ Installation Method:

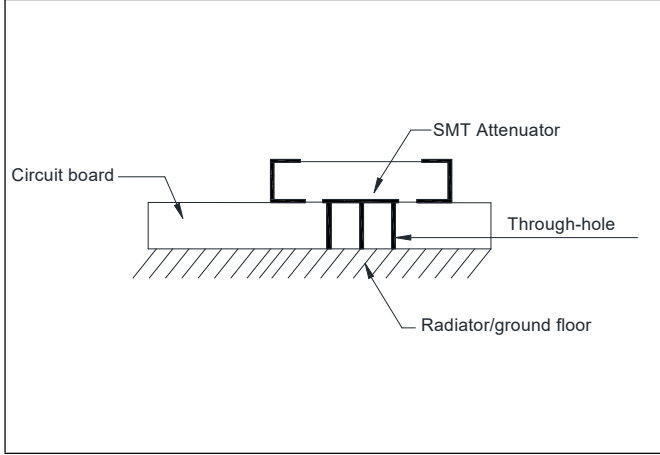

◆ Power De-rating:

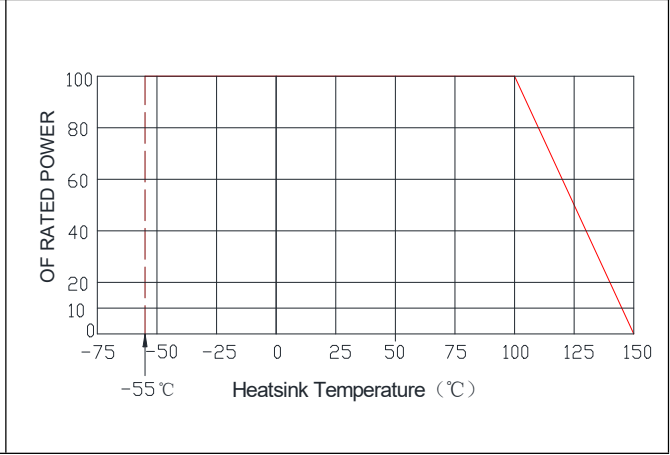

◆ Reflow soldering time & Temperature diagram:

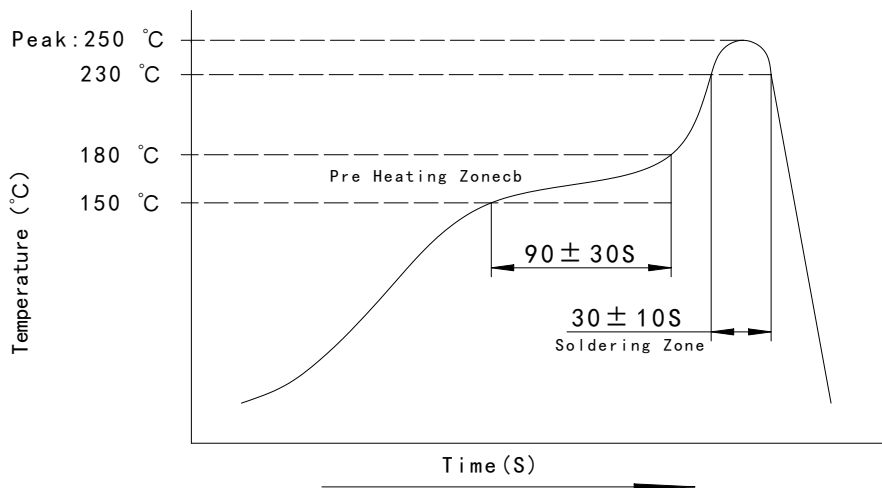

◆ P/N Designation:

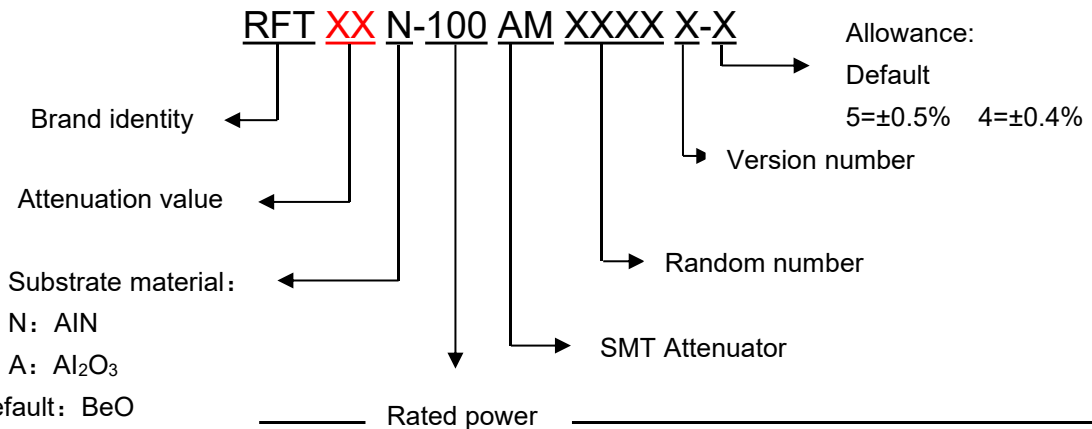



◆ **Notice:**

- After the storage period of newly purchased parts exceeds 6 months, attention should be paid to their weldability before use. It is recommended to store in vacuum packaging.
- Drill out the hot hole on the PCB and fill the solder.
- Reflow welding is preferred for bottom welding, please refer to Reflow introduction
- In order to meet the requirements of the drawings, a radiator of sufficient size must be installed.
- Add air cooling or water cooling if necessary.

◆ **Instructions:**

- Custom designed RF attenuators, RF resistors and RF terminals are available.
- In order to meet the requirements of the drawing, it is necessary to install a sufficiently large radiator. Metal surfaces and radiators need to be coated with a very thin layer of thermal grease.
- Add air cooling or water cooling if necessary.