



Coaxial Fixed Attenuator

Features and Electrical specifications:

Model	RFTXX-02RA0912-SMA-8 (XX=Attenuator Value)		
Frequency Range	DC~8.0GHz		
VSWR	1.20 Max		
Power	2 W		
Impedance	50 Ω		
Attenuation	1-10dB	15、20dB	25、30dB
Attenuation Tolerance	±0.6dB	±0.8dB	±1.0dB
Connector	SMA-J(M)/SMA-K(F)		
Dimension	Φ9×31mm		
Operating Temperature	-55 ~ +125°C (See de Power De-rating)		
Weight	About 8 g		
ROHS Compliant	Yes		

Outline Drawing (Unit: mm/inch):

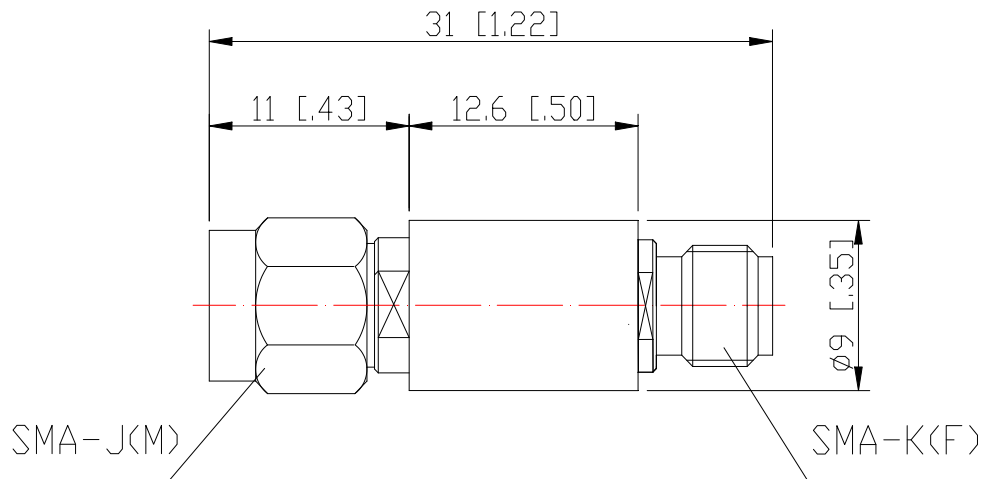



Naming rules:

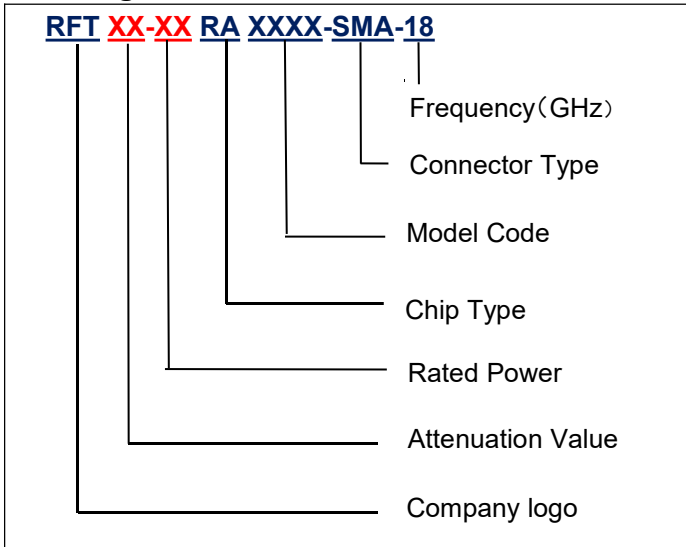

Power De-rating:

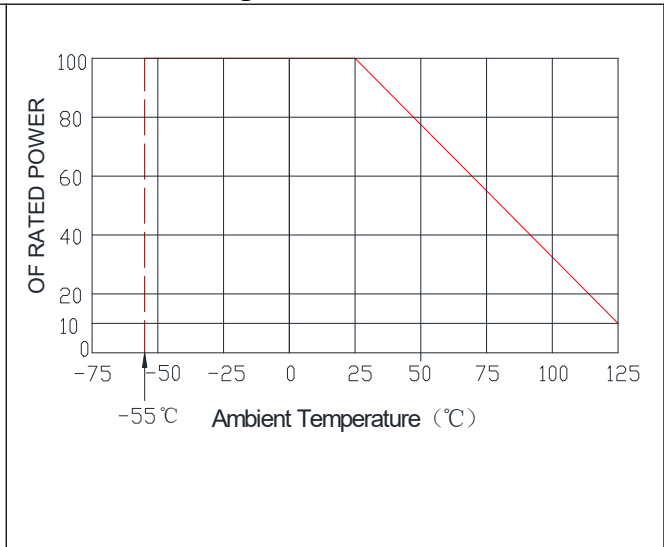

Graph:

3dB

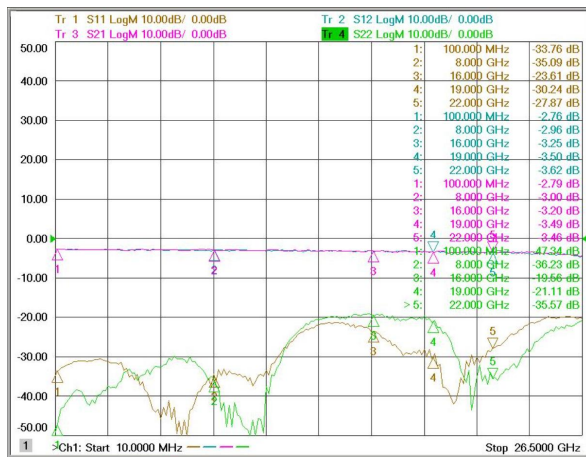

5dB

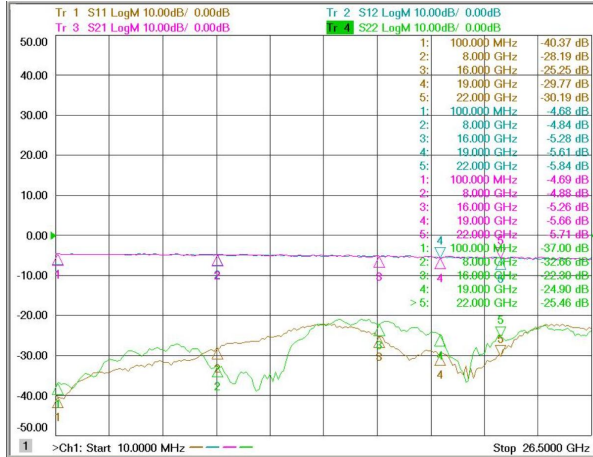

6dB

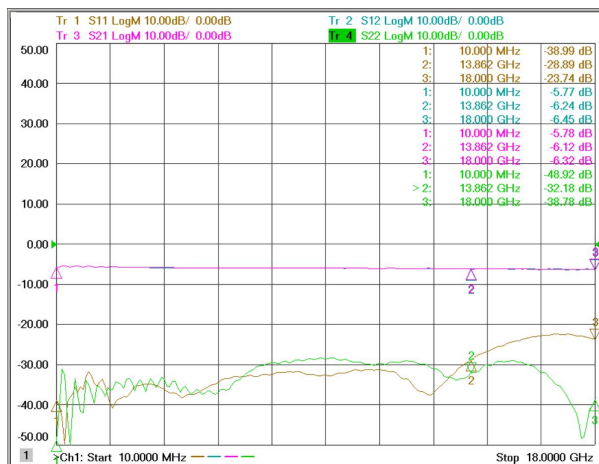

10dB

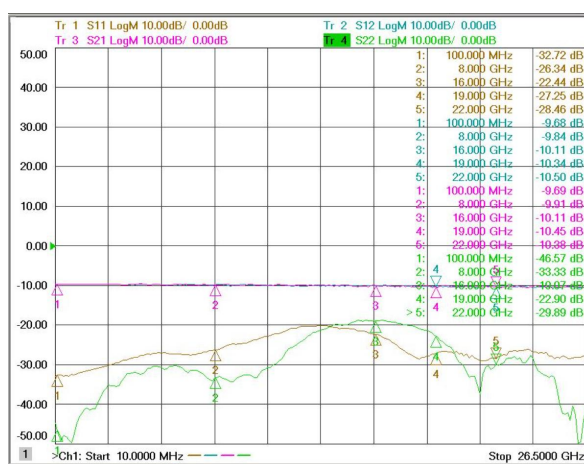



20dB

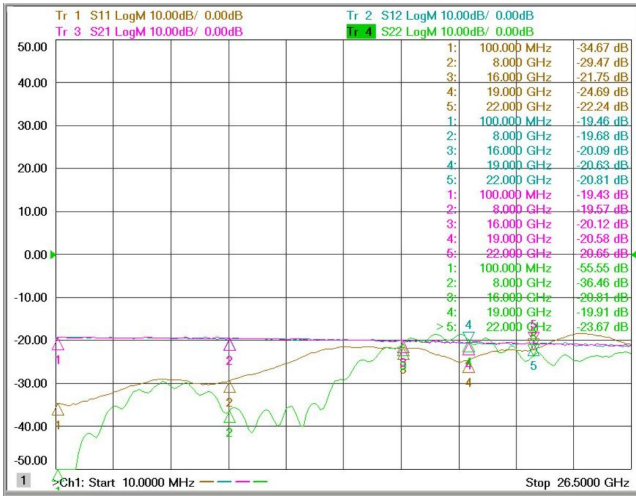

30dB

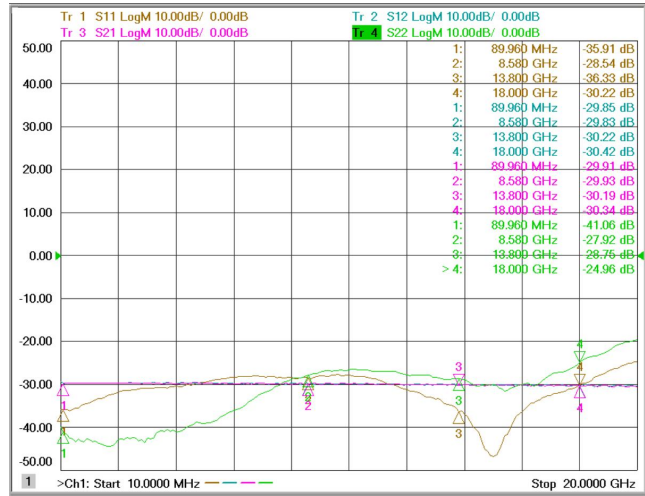

Use attention:

- 1、 Dimensions Tolerance $\pm 3\%$;
- 2、 If necessary, the product shall be air-cooled for auxiliary heat dissipation ;
- 3、 Custom designs available of other special coaxial fixed attenuator ;
- 4、 Pay attention to the direction of the product during use and strictly prohibit reverse connection.